

# OPERATION Allison 3000 Series

## Driving the Allison 3000 Series Transmission

Allison 3000 Series is a fully automatic transmission, featuring a torque converter with a lock up clutch and six (6) forward and one (1) reverse gear ratios.

### Procedure - Start Up

1. Ensure the park brake is applied.
2. Turn the ignition key to the ON position and observe that the check lamp function has momentarily illuminated the Automatic Transmission WARNING light.
3. Ensure the Range Selector is in the "N" ("NN" displayed).
4. Start the engine.

### Selecting a Starting Gear and Gear Shifting

1. Depress the brake pedal and with the engine at idle speed, select the required driving range ('R' or 'D', if required use the ▲/▼ buttons to select the desired forward operating range - refer Digital Display table) and then wait approximately 1 second for full gear engagement.
2. The Digital Display will then indicate the 'driver selected range' on the LHS and the 'actual engaged gear' on the RHS.
3. Set the vehicle in motion by releasing the brake pedal and then the park brake whilst progressively applying the accelerator pedal.
4. When moving in the forward direction all gear ratio changes are performed automatically within the parameters of the mode selected.
5. When stopping the vehicle at traffic lights etc. hold the brake pedal depressed to prevent the vehicle from forward or rearward movement.

### Procedure - Shut Down

1. Stop the vehicle and hold the brake pedal depressed.
2. With the engine stabilised to idle speed, select "N".
3. Apply the park brake.
4. Turn the ignition key to the OFF position and release the brake pedal.

Notes:

- **Neutral Safety Function:** The starter cannot be activated unless the Range Selector is in the 'N' position.
- **Range Shift Limit (engine and road speed) Function:** When shifting from 'N' to either a forward or reverse mode gear, the engine must be at idle speed and the vehicle stationary.

If this action is not adhered to the LHS of the Digital Display will 'flash repeatedly'. If this occurs, stop the vehicle, hold the brake pedal depressed and with the engine at idle speed, select 'N' mode and then reselect the desired driving mode.

- **Extended Idling:** To prevent overheating of the transmission, always select 'N' if you need to idle the engine for more than 5 minutes.

# OPERATION Allison 3000 Series

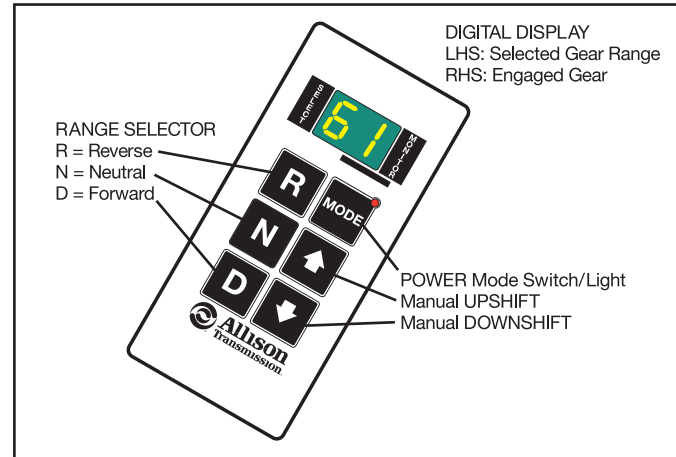

## R Reverse Mode

"R" mode is used for moving the vehicle rearwards.

When shifting from 'N' to 'R' mode, the engine must be at idle speed and the brake pedal depressed holding the vehicle stationary. Refer note; Range Shift Limit Function.

## N Neutral Mode

"N" mode is used when starting the engine, warming up the engine, extended idling periods and when stopped.

When shifting from 'N' to a driving range, the engine must be at idle speed and the brake pedal depressed holding the vehicle stationary.

Refer notes; Range Shift Limit Function and Extended Idling.

## D Forward Mode and ▲/▼ Uphill/Downshift Buttons

"D" mode is used for all forward driving.

Range	Digital Display		Mode
	LHS	RHS	
R	R	R	Reverse
N	N	N	Neutral
D	6	1 ~ 6 (a)	Normal forward driving
▼ Once	5	1 ~ 5 (a)	Is used when driving slowly in areas with heavy traffic or when an additional amount of engine braking is required for descending inclines.
▼ Twice	4	1 ~ 4 (a)	
▼ 3 times	3	1 ~ 3 (a)	
▼ 4 times	2	1 ~ 2 (a)	
▼ 5 times	1	1 (b)	

Notes: a) Shifting between the gears in the selected gear range is done automatically, according to engine load and road speed.

b) The transmission remains in 1<sup>st</sup> gear and does not shift.

# OPERATION Allison 3000 Series

## POWER Mode

When pushed once, the indicator (switch and dash panel) lights illuminate and the transmission selects POWER mode. This mode raises the gear shift points under both light and heavy vehicle acceleration modes.

Note: Excessive use of POWER mode may increase fuel consumption.

## WARNING LIGHTS

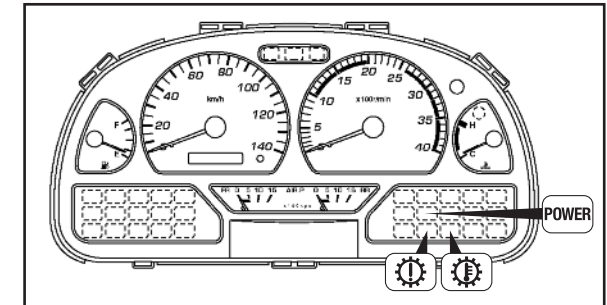

## Automatic Transmission SHIFT LIMIT

Under the following conditions, the ECU prohibits gear shifting for the purpose of protecting the transmission.

- Engine speed is greater than 1000 rpm when shifting from 'N'.
- Forward/Reverse Changeover: When the vehicle is moving and exceeds the specified speed.
- When the ECU receives an abnormal request signal, gear shifting is limited to protect the transmission from damage.

## Automatic Transmission FLUID TEMPERATURE

If the transmission fluid temperature rises above approximately 121°C, the warning light will illuminate and the warning buzzer will sound.

**CAUTION:** If the fluid temperature warning is activated, stop the vehicle, select 'N' mode and then operate the engine at 1200 ~ 1500 rpm until the fluid temperature returns to normal. It is also recommended that the transmission fluid level be checked - refer Misc. Items.

## Automatic Transmission WARNING

The warning light illuminates when the transmission ECU detects a fault in the transmissions operation.

- ECU Reset Procedure (clearing intermittent faults): Select 'N' mode, turn the ignition switch to the OFF position and then restart the engine.

**NOTE:** If any of the above warning lights remain illuminated, contact your UD Trucks dealer for assistance (ph. 1300 289 283).

## DRIVING TIPS Allison 3000 Series

### Exhaust Brake - Performance

When using the exhaust brake to retard the vehicle and increased engine braking performance is required use the '▲/▼' buttons to select and hold an appropriate gear range.

### Descending Inclines

Taking into consideration the vehicle load and gradient conditions, use the '▲/▼' buttons to select an appropriate gear range that in combination with the exhaust brake and intermittent application of the brake pedal will maintain a vehicle speed within the engine governed speed range (up to 2550 rpm).

**CAUTION:** DO NOT EXCEED THE ENGINE GOVERNED SPEED IN A LOWER GEAR RANGE AS THE TRANSMISSION MAY UPSHIFT TO THE NEXT HIGHER GEAR RANGE, RESULTING IN DIMINISHED VEHICLE CONTROL.

### Cruise Control

- Cruise control can only be set or resumed between 35 ~ 100 km/h and when activated, the auto cruise control will continue to function within its operating range as the transmission automatically changes gear ratios.
- When driving in auto cruise, cruise control is cancelled when;
  - a) the vehicle speed drops below approximately 35 km/h or by the momentary operation of the
  - b) exhaust brake or
  - c) brake pedal.
- Once cancelled, it requires the driver to manually reactivate the cruise control by either pressing the RESUME switch if the original speed is required or the SET switch once the desired vehicle cruise speed is attained.

**CAUTION:** AS THE CRUISE CONTROL IS CANCELLED AUTOMATICALLY WHEN THE VEHICLE SPEED DROPS BELOW APPROXIMATELY 35 KM/H THE VEHICLE MAY LOSE ROAD SPEED RAPIDLY.

WHEN **CLIMBING HILLS** IT IS RECOMMENDED THAT THE DRIVER OVERRIDE THE CRUISE CONTROL BY APPLYING PRESSURE TO THE ACCELERATOR PEDAL.

### Power Take Off (PTO)

When equipped with a transmission PTO, ensure that the PTO manufacturer's operating instructions are adhered to.

## MISC. ITEMS Allison 3000 Series

### Transmission Fluid (oL) Level – Check Procedure

- Warm up the engine to normal operating temperature.
- Ensure the Range Selector is in the "N" ('N N' displayed) position.
- With the vehicle stationary, idle the engine for approximately 2 minutes.
- Then simultaneously push the ▲ and ▼ buttons on the selector.



- If the above conditions have been satisfied, the results will be displayed in the Digital Display as a sequence of 3 codes, a typical low fluid level sequence being 'oL' 'L o' 'l' - refer the following table.

Fluid Level Codes		Fluid Level
o L	H l	Fluid level too high (l unit = 1.0 litre)
	o K o K	Fluid level OK
	L o l	Fluid level too low (l unit = 1.0 litre)

- If conditions for checking the transmission fluid level are not satisfied one of the following fault codes will be displayed. To recover the fluid level check mode, select 'N' and repeat the fluid level check procedure.

Fault Codes		Condition	
o L	--	E H	Engine speed (rpm) too high
		E L	Engine speed (rpm) too low
		F L	Sensor failed
		S H	Output shaft rotation (vehicle not stationary)
		S N	N (neutral) must be selected
		T H	Sump fluid temperature too high
		T L	Sump fluid temperature too low
X #	Waiting period is not complete # is a flashing numeral, counting down from 8 to 1 until the waiting period is complete.		

### Optional Features (contact your UD Trucks dealer for details)

To accommodate special vehicle applications, it is feasible to have the transmission ECU reprogrammed to include either one of or a combination of the listed optional features.

• Exhaust Brake Interface:	Recommended for general duty cargo/distribution truck, reduces reliance on the service brakes.
• Range Shift Inhibit:	Recommended for additional transmission protection where the vehicle application incorporates a high degree of forward/rearward direction changes.
• Direction Change Inhibit:	
• Rolling Change Inhibit:	



## Driver Instructions PK9 & PK10 Models with Allison 3000 Series 6-Speed Automatic Transmission



UD Trucks  
120 Hume Highway  
CHULLORA NSW 2190

P/No. AUS000154  
Mar-09